

IMPORTANT SAFEGUARDS

SAVE AND READ THESE INSTRUCTIONS

When using electrical appliances, basic safety precautions should always be followed including the following:

- **READ ALL INSTRUCTIONS, PRODUCT LABELS AND WARNINGS BEFORE USING THE TOASTER OVEN.**
- Do not touch hot surfaces. Always use oven mitts when handling hot materials and allow metal parts to cool before cleaning. Allow the unit to cool thoroughly before putting in or taking off parts. Always use the oven handles when moving the unit.
- When the unit is not in use and before cleaning, unplug the toaster oven from the wall outlet. **Note:** Make sure the oven is turned off before unplugging.
- To protect against risk of electrical shock, do not immerse the appliance in water or any other liquids.
- Close supervision is always necessary when this or any appliance is used near children. This appliance is not for use by children.
- Do not operate this or any appliance with a frayed or damaged cord or plug or after the appliance malfunctions or is dropped or has been damaged in any manner. Return appliance to the nearest authorized service facility for examination, repair or adjustment.
- Do not use attachments not recommended by the manufacturer; they may cause fire, electric shock or personal injury.
- Do not use outdoors or for commercial purposes.
- Do not use this appliance for other than its intended use.
- Do not let the cord dangle over the edge of a tabletop or countertop or touch hot surfaces.
- Do not place the appliance near a hot gas or electric burner or in a heated oven.
- Extreme caution should be used when using containers constructed of material other than metal or glass.
- A fire may occur if the toaster oven is covered or touching flammable materials, including curtains, draperies, walls, etc., when in operation. Do not store any items on top of the appliance when in operation.
- When using toaster oven, pull the unit out a minimum of 6 inches away from walls on all sides. Remove cords from other products from behind toaster oven.
- Do not store any materials, other than manufacturer’s recommended accessories, in this unit when not in use.
- Do not place any flammable materials in oven, such as paper, cardboard, plastic or any materials that may catch fire or melt.
- Do not cover the crumb tray or any part of the oven with metal foil. This will cause overheating of the appliance.
- Oversized foods or metal utensils must not be inserted in the appliance as they may create a fire or risk of electrical shock.
- Do not clean with metal scouring pads. Pieces can break off the pad and touch electrical parts involving a risk of electrical shock.
- Use extreme caution when removing tray or disposing of hot grease.
- To turn this appliance off, press Stop/Cancel button twice.
- To disconnect, press Stop/Cancel button twice to turn unit off, then remove plug from wall outlet.
- Extreme caution must be used when moving an appliance containing hot oil or other hot liquid.

THIS UNIT IS FOR HOUSEHOLD USE ONLY SHORT POWER SUPPLY CORD INSTRUCTIONS

A short power-supply cord is provided to reduce the risk resulting from becoming entangled in or tripping over a longer cord. An extension cord may be used if care is exercised in its use. If an extension cord is used, the electrical rating of the cord must be at least as great as the electrical rating of the appliance. The extension cord should be arranged so that it will not drape over the countertop or tabletop where it can be pulled on by children or tripped over unintentionally.

English-1



User Manual

French Door Countertop Oven

Manual de Instrucciones

Horno para mostrador con puerta francesa

MODEL/MODELO

TSSTTVFDDG



Visit us at www.oster.com

P.N. 180803

For Products Purchased in the United States and Canada Only

To reduce the risk of electrical shock, this appliance has a polarized plug (*one blade is wider than the other*). This plug fits a polarized outlet only one way; if the plug does not fit fully into the outlet, reverse the plug. If it still does not fit, contact a qualified electrician. **Do not** attempt to modify the plug in any way.

SAVE THESE INSTRUCTIONS

Welcome

Congratulations on your purchase of an OSTER® Toaster Oven!

Features of Your Toaster Oven

(See Figure 1)

1. Removable Wire Racks/Broil Rack
2. Interior Light
3. Time Display
4. Control Buttons
5. Two Rack Positions
6. Easy Clean Interior Walls
7. Glass Doors
8. Internal Removable Crumb Tray
9. Baking Pan

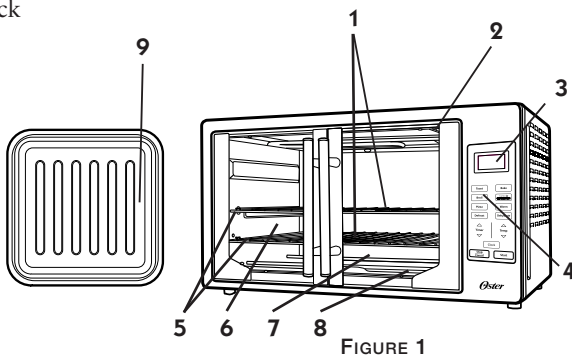

FIGURE 1

Control Buttons

1. Function Buttons – (See Figure 2)

Bake – Select to bake.

Turbo – Select to bake with convection.

Broil – Select to Broil.

Toast – Select to toast bread, bagels, etc.

Pizza – Select to bake up to 16” pizza.

Defrost – Select to defrost foods.

Dehydrate – Select to dehydrate foods

Timer $\Delta \nabla$ – Adjusts time, temperature or toast shade.

Temp $\Delta \nabla$ – Adjusts temperature.

Clock – Sets the Oven Clock.

Stop/Cancel – Stops heating or cancels function.

Start – Starts baking/cooking process.

NOTE – Oven is on when display icons are illuminated and flashing.

Pressing Stop/Cancel button twice turns off unit.



FIGURE 2

English-2

Positioning Rack

To accommodate a wide variety of foods, the oven has 2 racks and two (2) rack positions. (See Figure 3)

Positioning of the rack will depend on the size of the food and desired browning.

Before removing the rack, allow the unit to cool.

PLEASE NOTE – For best toast and pizza results, position the rack in the top rack position.

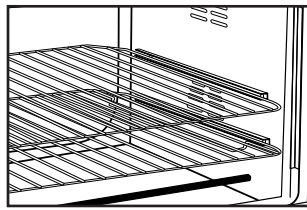
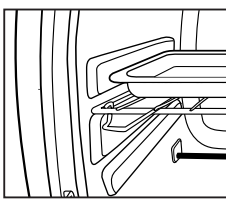

FIGURE 3

Positioning Pan

- To accommodate a wide variety of foods the oven has two pan positions. The pan can be placed on top of the rack or inserted into the guide rails below the rack. (See Figure Below)
- Before removing the pan allow the unit to cool.
- Positioning of the oven pan will depend on the desired cooking method. For baking, place the pan on top of one of the racks. For grilling or broiling, insert the pan into the guide rails below the rack and place the food on top of the rack.

PLEASE NOTE – Do not to use the broil pan under the rack in the lower position.



For Baking

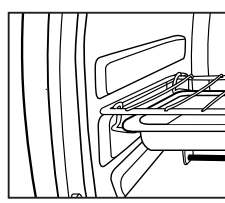

For Grilling or Broiling

Cleaning Your Toaster Oven

Before cleaning your OSTER® Toaster Oven, press Stop/Cancel button twice, unplug it and allow it to cool. To clean, wipe with damp cloth. **DO NOT IMMERS E IN WATER!** Make sure to use only mild, soapy water. Abrasive cleaners, scrubbing brushes and chemical cleaners will damage the coating on this unit. Empty crumb tray frequently to avoid accumulation of crumbs. Toaster oven racks are dishwasher safe (*top of dishwasher only*).

Storing Your Toaster Oven

Allow the appliance to cool completely before storing. If storing the toaster oven for long periods of time make certain that the toaster oven is clean and free of food particles. Store the toaster oven in a dry location such as on a table or countertop or cupboard shelf. Other than the recommended cleaning, no further user maintenance should be necessary.

English-5

Preparing To Use Your Toaster Oven for the First Time

If you are using your toaster oven for the first time, please be sure to:

Remove any stickers from the surface of the oven.

Open oven door and remove all printed documents and paper from inside the toaster oven.

Clean the rack, tray, and pan with hot water, a small amount of dishwashing liquid and a non-abrasive sponge or cleaning pad.

DO NOT IMMERS E THE BODY OF THE UNIT IN WATER.

Dry the unit thoroughly before using.

Select a location for the toaster oven. The location should be in an open area on a flat counter where the plug will reach an outlet.

Plug the toaster oven into a 120 Volt AC electrical outlet.

Using Your Toaster Oven

Setting the Clock

Push the Clock button. The clock will flash.

Use the arrow keys to set the hour. Push the Clock button again.

Use the arrow keys to set the minutes.

Push the Clock button once more or the start button and the time will be set.

Preheating the Oven

Place oven rack into the desired position before heating the oven. (See “Positioning Rack” Section)

This oven has a preheat feature in Turbo Convection Bake and Bake mode. Select the mode, Turbo Convection or Bake. Use the temp arrow keys to select the desired temperature. Use the timer arrow keys to select the desired time.

Push the Start button. Display will show PrE until temperature is reached, the oven will beep and display remaining time. At this time you may adjust the selected time. The temperature may also be adjusted. If you increase the temperature the unit will go back to preheat mode until it reaches the new set temperature.

To bypass the preheat function press the start button a second time.

To Use the Bake Function

Place oven rack into the desired position before heating the oven. (See “Positioning Rack” Section)

Arrange food on the wire rack or in the baking pan.

Push the Bake button. Use the Temperature arrow keys to select desired temperature.

Use the Time arrow keys to select desired time.

Push the Start button.

The oven will go into the preheat mode. To bypass the preheat mode press the start button a second time.

Interior light turns on when timer is on. At the end of cooking cycle the light turns off automatically.

NOTE – Upper and lower heating elements will cycle ON and OFF to maintain the desired temperature, and may not glow.

When baking is completed, open door fully and remove food carefully.

To Use the Convection Fan Bake Function

When you select the Convection Bake the convection fan will turn on and circulate air allowing the food to cook evenly and faster.

Place oven rack into the desired position before heating the oven. (See “Positioning Rack” Section)

Arrange food on the wire rack or in the baking pan.

Push the Convection Bake button until “Convection Bake” lights up on display. Use the Temp arrow keys to select desired temperature.

Push Timer arrow keys to select desired time.

Push the Start button.

The oven will go into the preheat mode. To bypass the preheat mode press the start button a second time.

English-3

HELPFUL TIPS / TROUBLESHOOTING		
PROBLEM	POTENTIAL CAUSE	SOLUTION
• Overcooked / Undercooked Foods	• Incorrect temperature or time setting • Rack placement	• You may have to adjust the time and temperature to desired taste. • Because your toaster oven is smaller than your regular oven, it will heat up faster and generally cook in shorter periods of time. • Refer to “Positioning Rack” Section, Page English-4. Rack may need to be adjusted to accommodate food type.
• Burnt Smell	• Food build-up inside oven, on heating elements or in crumb tray.	• Refer to “Cleaning Your Toaster Oven” Section, Page English-5.
• Oven does not turn ON	• Unit is unplugged • Did not press Start.	• Plug the toaster oven into a 120-volt AC electrical outlet. • Set timer knob and temperature knob to desired setting. Both must be turned on to operate the toaster oven. • Press Start.
• Only one heating element is heating up	• Function setting selection determines which heating element will operate.	• When toasting, make sure the oven is not set to broil setting.
• Heating elements do not stay ON	• Heating elements will cycle ON and OFF to maintain proper heat.	• Be certain that function is as desired. • Heating elements may not glow.
• Cannot change function button	• Need to cancel function.	• Press cancel.

English-4

Interior light turns on when timer is on. At the end of cooking cycle the light turns off automatically.

NOTE – Both heating elements will cycle ON and OFF to maintain the desired temperature, and may not glow.

When baking is completed, open door fully and remove food carefully.

To Use the Broil Function

Place the pan into the guide rails below the rack and place the food on top of the rack.

(See “Positioning Rack” Section)

Place broil rack in oven.

Push Broil button until the word “Broil” lights up on display.

Push Timer arrows to select the desired time.

Push the Start button.

Interior light turns on when timer is on. At the end of cooking cycle the light turns off automatically. **NOTE** – The top heating element will cycle ON and OFF to maintain desired temperature, and may not glow.

When broiling is completed, open door fully and remove food carefully. **WARNING: DO NOT LEAVE TOASTER OVEN UNATTENDED.**

To Use the Toast Function

Place oven rack into the desired position before heating the oven. (See “Positioning Rack” Section)

NOTE – Different types of bread require different settings. Lighter breads and waffles require a lighter setting. Darker breads, muffins, and English muffins require a darker setting. Arrange food on the wire rack.

Push the Toast button. Use arrows to select Toast Shade.

Push the Start button.

When toasting is completed, open door fully and remove food carefully.

To Use the Pizza Function

Place oven rack into the desired position before heating the oven. (See “Positioning Rack” Section)

Arrange pizza on the wire rack.

Push the Pizza button and 20:00 default time will appear. Use arrow keys to adjust the time as desired. Push the Start button.

Interior light turns on when timer is on. At the end of cooking cycle the light turns off automatically.

NOTE – The Pizza function temperature is set at 400°F and cannot be adjusted.

If different temperature is desired, cancel Pizza function and use Bake function.

For 2 Pizzas: Place the 2 pizzas on the wire racks. Cook the pizzas for about one-half the recommended time, and then switch the rack positions to allow the pizzas to uniformly cook top and bottom.

Defrosting Function

When defrosting do not preheat oven. Temperature Control is already set to 150°F and cannot be adjusted.

Push the defrost button. Use arrow keys to adjust time. Allow 15 to 20 minutes per side for meats or fish to defrost. Always cook food promptly after thawing.

Push the Start button.

Interior light turns on when timer is on. At the end of cooking cycle the light turns off automatically.

Dehydrate Function

When dehydrating do not preheat oven. Temperature Control is already set to 150°F and cannot be adjusted. Push the dehydrate button. Use arrow keys to adjust time. Dehydrate time can be adjusted up to 6hrs. Push the start button to start dehydrating.

For more information on dehydrating food, please visit www.oster.com

1 Year Satisfaction Guarantee

Sunbeam Products, Inc. doing business as Jarden Consumer Solutions or if in Canada, Sunbeam Corporation (Canada) Limited doing business as Jarden Consumer Solutions (collectively “JCS”) warrants that for a period of one year from the date of purchase, this product will be free from defects in material and workmanship. JCS, at its option, will repair or replace this product or any component of the product found to be defective during the guarantee period. Replacement will be made with a new or remanufactured product or component. If the product is no longer available, replacement may be made with a similar product of equal or greater value. This is your exclusive guarantee. Do NOT attempt to repair or adjust any electrical or mechanical functions on this product. Doing so will void this guarantee. This guarantee is valid for the original retail purchaser from the date of initial retail purchase and is not transferable. Keep the original sales receipt. Proof of purchase is required to obtain satisfaction guarantee performance. JCS dealers, service centers, or retail stores selling JCS products do not have the right to alter, modify or any way change the terms and conditions of this guarantee.

This guarantee does not cover damage resulting from any of the following: negligent use or misuse of the product, use on improper voltage or current, use contrary to the operating instructions, disassembly, repair or alteration by anyone other than JCS or an authorized JCS service center. Further, the guarantee does not cover: Acts of God, such as fire, flood, hurricanes and tornadoes.

What are the limits on JCS's Liability?

JCS shall not be liable for any incidental or consequential damages caused by the breach of any express, implied or statutory guarantee or condition. Except to the extent prohibited by applicable law, any implied guarantee or condition of merchantability or fitness for a particular purpose is limited in duration to the duration of the above guarantee. JCS disclaims all other guarantees, conditions or representations, express, implied, statutory or otherwise. JCS shall not be liable for any damages of any kind resulting from the purchase, use or misuse of, or inability to use the product including incidental, special, consequential or similar damages or loss of profits, or for any breach of contract, fundamental or otherwise, or for any claim brought against purchaser by any other party.

Some provinces, states or jurisdictions do not allow the exclusion or limitation of incidental or consequential damages or limitations on how long an implied guarantee lasts, so the above limitations or exclusion may not apply to you. This guarantee gives you specific legal rights, and you may also have other rights that vary from province to province, state to state or jurisdiction to jurisdiction.

How to Obtain Satisfaction Guarantee Service

In the U.S.A.

If you have any question regarding this guarantee or would like to obtain guarantee service, please call 1-800-334-0759 and a convenient service center address will be provided to you.

In Canada

If you have any question regarding this guarantee or would like to obtain guarantee service, please call 1-800-667-8623 and a convenient service center address will be provided to you.

In the U.S.A., this guarantee is offered by Sunbeam Products, Inc. doing business as Jarden Consumer Solutions located in Boca Raton, Florida 33431. In Canada, this guarantee is offered by Sunbeam Corporation (Canada) Limited, located at 20 B Hereford Street, Brampton, Ontario L6Y 0M1. If you have any other problem or claim in connection with this product, please write to the Consumer Service Department.

PLEASE DO NOT RETURN THIS PRODUCT TO ANY OF THESE ADDRESSES OR TO THE PLACE OF PURCHASE.

For product questions contact: Jarden Consumer Service - USA: 1.800.334.0759 - Canada: 1.800.667.8623 - www.oster.com © 2013 Sunbeam Products, Inc. doing business as Jarden Consumer Solutions. All rights reserved. Distributed by Sunbeam Products, Inc. doing business as Jarden Consumer Solutions, Boca Raton, Florida 33431. Jarden Consumer Solutions is a subsidiary of Jarden Corporation (NYSE: JAH) Printed in China.

Para preguntas sobre los productos llame: Jarden Consumer Service - EE.UU.: 1.800.334.0759 - Canadá: 1.800.667.8623 - www.oster.com © 2013 Sunbeam Products, Inc. operando bajo el nombre de Jarden Consumer Solutions. Todos los derechos reservados. Distribuido por Sunbeam Products, Inc. operando bajo el nombre de Jarden Consumer Solutions, Boca Raton, Florida 33431. Jarden Consumer Solutions es una subsidiaria de Jarden Corporation (NYSE: JAH) Impreso en China. CIA-042415

English-6

